

HOW TO ORDER COMBINATION CHANNEL

Example

E1001 H



Select Combination Channel

- E1001** 41x82.6mm/2.5mm THK, Combination
- E2001** 41x82.6mm/1.6mm THK, Combination, Ribbed
- E3301** 41x43.2mm/2.5mm THK, Combination
- E4001** 41x43.2mm/1.6mm THK, Combination, Ribbed
- E5501** 41x123.8mm/2.5mm THK, Combination

Select Finish*

- M** Mill Steel
- G** Pre-Galvanised
- H** Hot Dip Galvanised
- S** Stainless Steel
- A** Aluminium

* Refer to each channel for available finishes and service guide.

D OTHER STRUT COMBINATIONS AVAILABLE AS MADE TO ORDER.

E1001 COMBINATION CHANNEL

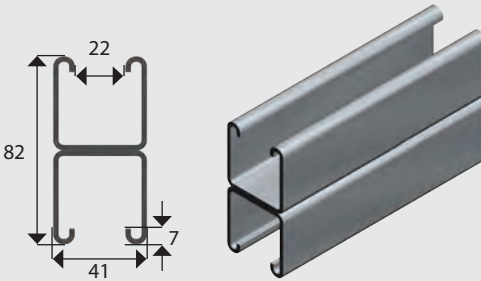

HEAVY DUTY

- Supplied in 6m lengths
- 41x82mm
- 2.5mm THK

Available Finish	Weight	Part Number	Service Guide
M	31.2kg/6m	E1001M	C
G	30.0kg/6m	E1001G	C
H	31.8kg/6m	E1001H	A
A	32.0kg/6m	E1001A	C

The channel is continuously spot welded at a maximum of 150mm centres.

E2001 COMBINATION RIBBED CHANNEL

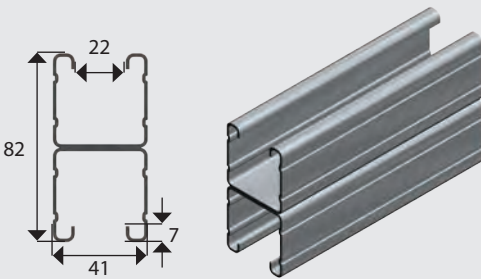

MEDIUM DUTY

- Supplied in 6m lengths
- 41x82mm
- 1.6mm THK

Available Finish	Weight	Part Number	Service Guide
G	10.7kg/6m	E2001G	D
H	11.4kg/6m	E2001H	D
A	7.2kg/6m	E2001A	D

The channel is continuously spot welded at a maximum of 150mm centres.

Service Guide Key: **A** Usually in stock at all branches **B** Usually in stock at head office
C Normal lead time **D** Made to Order (lead time on enquiry)

FASTENERS

STRUT SYSTEMS

CABLE SUPPORTS

FIRERATED

PIPE SUPPORTS

E3301 COMBINATION CHANNEL

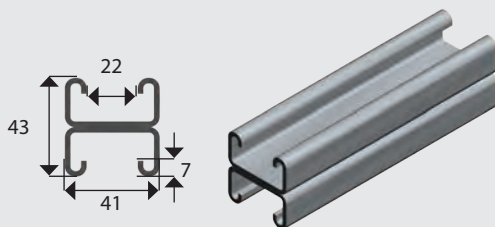

MEDIUM DUTY

- Supplied in 6m lengths
- 41x43mm
- 2.5mm THK

Available Finish	Weight	Part Number	Service Guide
M	20.2kg/6m	E3301M	D
G	19.4kg/6m	E3301G	D
H	21.4kg/6m	E3301H	C
S	20.6kg/6m	E3301S	D

The channel is continuously spot welded at a maximum of 150mm centres.

E4001 COMBINATION RIBBED CHANNEL

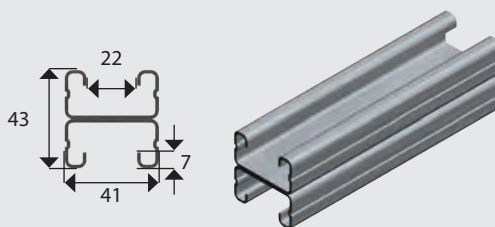

LIGHT DUTY

- Supplied in 6m lengths
- 41x43mm
- 1.6mm THK

Available Finish	Weight	Part Number	Service Guide
M	15.4kg/6m	E4001M	C
G	15.4kg/6m	E4001G	D
H	16.3kg/6m	E4001H	D
A	5.1kg/6m	E4001A	D

The channel is continuously spot welded at a maximum of 150mm centres.

E5501 COMBINATION CHANNEL

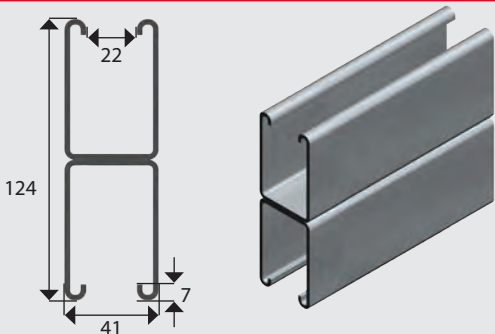

VERY HEAVY DUTY

- Supplied in 6m lengths
- 41x124mm
- 2.5mm THK

Available Finish	Weight	Part Number	Service Guide
G	39.5kg/6m	E5501G	D
H	43.2kg/6m	E5501H	C

The channel is continuously spot welded at a maximum of 150mm centres.

FASTENERS

STRUT SYSTEMS

CABLE SUPPORTS

FIRERATED

PIPE SUPPORTS